



United Technologies

Carucco™ range

Cabrio™ Convertible Counter

Flexible merchandise
for every market situation



Attractive, modern appearance

Multi-functional design

Easy transformation from serve-over to self-service

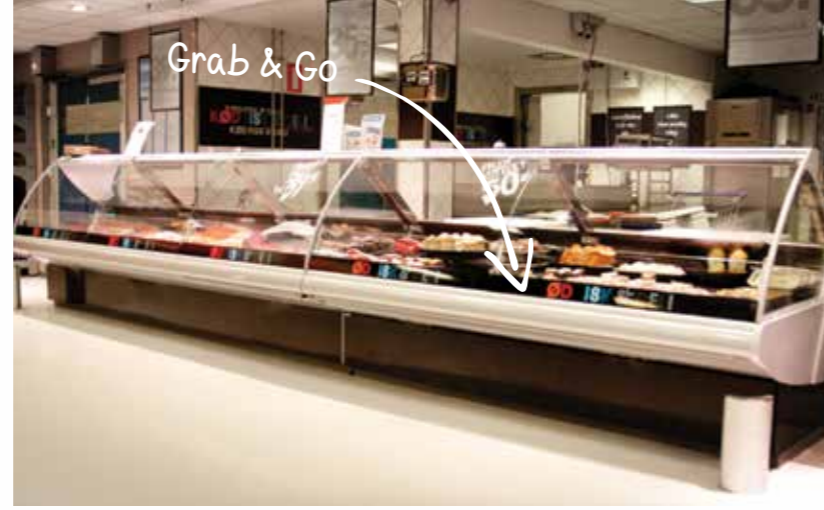

In today's stores, meeting the demand for flexibility, uniqueness and variability is essential. All of these benefits are available in the Cabrio™, a convertible counter that allows for enhanced store efficiency and tremendous adaptability.

Smart solution

Easy adjustment from self-service to serve-over by simply pushing the front glass.
No specialized technicians required.

Benefits at a glance

- Flexibility to meet a variety of store applications
- Easily convertible from self-service to serve-over
- Plug-in version for easy relocation
- Enhanced merchandising with horizontal or inclined display
- Simplified maintenance for everyday use
- Ergonomic design for staff comfort and accessibility

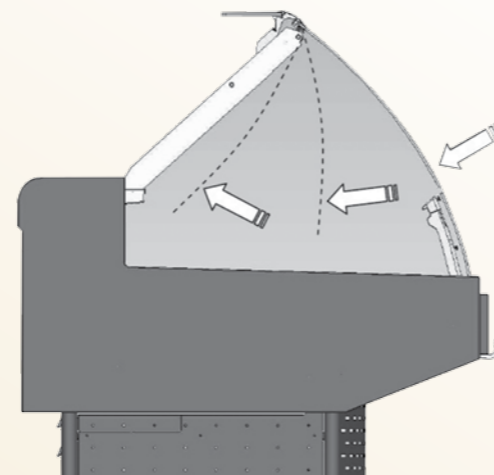

Cabrio, the smart solution

Multi-functionality

- The built-in multi-functionality of the Cabrio counter offers maximal use of the given floor space.
- The demands of serve-over, self-service and promotional placement in a shop can be satisfied with the purchase of only one counter.

Ergonomics

- The shop operator can carry out operations efficiently with a convertible counter.
- A new soft tummy bumper profile is developed as a multi-purpose channel for electrical cables supplying power to the scales and other electric equipment.
- Trenchers, paper holders and other accessories are moveable and functional parts of the counter.

Design

- The aesthetic design of the Cabrio plays an essential role in the functionality and attractive product presentation combined in one counter.
- An aesthetically-pleasing design is inherently impressive, however, the Cabrio also puts the product to the fore. Three different configurations provide retailers with extended design flexibility.
- Stainless steel materials deliver high quality and an elegant touch.

Energy efficiency

- The use of high-performance fans and fan speed control saves energy, reduces operating costs and respects the environment.
- Developments include a new control unit that drives the performance characteristics of the overall unit to ensure efficient operation.



*CB aesthetics (bumper as optional feature)



*E5 aesthetics (metal inlay available feature for side wall)



*I6 aesthetics



Polyethylene cutting board



Paper tray



Knife holder

*Aesthetics: different side wall and front side versions. E5 design allows harmonious integration into existing store layout with E5 cabinets.

Product overview

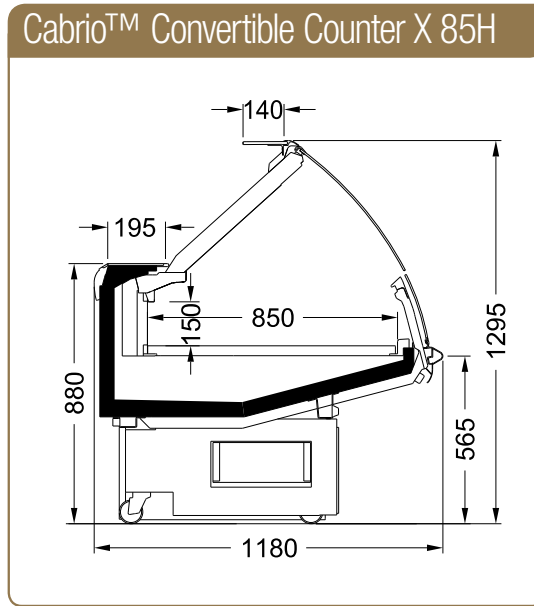
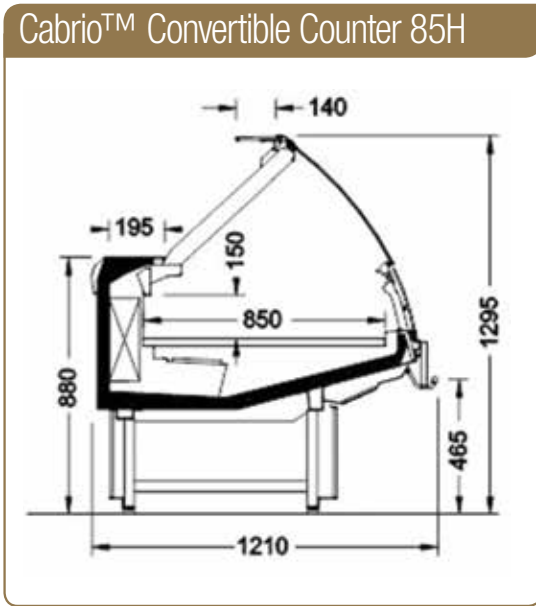

Plug-in versions available with wheels for size 125, 188
 Plug-in versions available with standard base (w/o wheels) for size 125, 188, 250, 375

Product features

- Fan assisted air circulation
- 1 display deck (850 mm)

Fitted with:

- Evaporator R404A protected by cataphoresis
- Energy saving fans
- Air discharge
- Solar digital thermometer
- Terminal block for electrical connections

Options:

- E5 / CB / I6 / wood aesthetic
- Cabinet with pedestals
- LED lighting

How to read the product name?

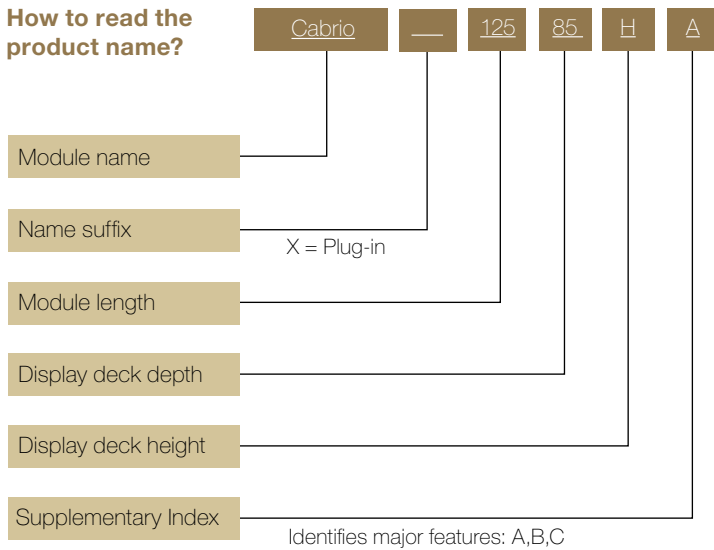

For more detailed information, see Carrier's Counter Range Overview brochure.



Cabrio. 85H A / X85 H	Modules			
	125	188	250	375
Total display area (m²)				
	1.06	1.59	2.13	3.19
Temperature range* (°C)	0/+2 +2/+4 +4/+6			

* These temperature ranges are shown in general for the refrigerated cabinets. Please refer to the technical manual to match the right temperature range to the different versions.